



SR (SuperRacer)

User Manual

Zhengzhou Chaokuo Electronic Technology Co., Ltd.

Contents

A	A-1 Advice And Guidance-----	1	M	M-1 Upload Firmware-----	28
B	B-1 Parameters -----	2	N	N-1 Trouble Shooting-----	29
C	C-1 Introduction-----	3	O	O-1 Motherboard Wiring Diagram-----	31
D	D-1 Packing List·Main Parts-----	4	P	P-1 Maintenance-----	32
	D-2 Packing List·Gift Parts List-----	5			
E	E-1 Assembly Instructions-----	6			
F	F-1 Switch Input Voltage-----	12			
G	G-1 Auto Leveling-----	13			
H	H-1 Upload Filament-----	16			
I	I-1 First Layer Verification-----	18			
J	J-1 Install Slicing Software-----	20			
K	K-1 Printing-----	22			
L	L-1 Touch Screen Instructions-----	25			



- 1.The printer's default power input voltage is 230V,if your local voltage is 115V, please switch the input voltage of the power supply before turning on the printer for the first time.
- 2.The assembly videos, firmware and slicing software are included in the SD card, please back up the files of the SD card to your computer before using.
- 3.Do not touch the hot bed and nozzle while the printer is running,as the heat would cause the burn injuries to your skin.
- 4.The printer's environment can affect the print quality, please ensure the printer is not placed in too hot/cold temperature, high humidity or near drafts.To ensure optimum printing, place the printer on an even and firm surface.
- 5.Failures caused by changes to the printers mechanical components are not covered by the printers warranty.
- 6.Keep young children away from the printer due to the hot components while printer is running.
- 7.Please use the recommended filaments , poor quality filaments may cause poor print quality or damage the printer.
- 8.Typical maintenance would be usefull.
- 9.Please wait for the hot bed to cool down completely before removing the print.
- 10.In case of emergency,turn off the printer and pull it from the main power to prevent damage to the printer then contact our technical support.
- 11.To avoid damage to printer and property,do not misuse printer.Printer has been designed for it's intended purpose only.
- 12.All printers have been tested before leaving the factory.As a result of these tests,some filament and stain might remain in and around nozzle,this is normal.
- 13.In order to make the model stick to the hot bed well, please clean the hot bed before each print.
- 14.When the printer has to be restored to factory settings, please restart the printer first, and then click "Restore".



Model	FLSUN SuperRacer
Printing Size	Φ260*330 (Max) mm
Molding Tech	Delta FDM
Nozzle Diameter	Standard 0.4mm
Slice Thickness	0.05-0.3mm
Precision	±0.1mm
Filament Support	PLA/ABS/PETG/WOOD
File Format	STL/OBJ/AMF/3DS
Print Speed	Default Speed 150mm/s
Nozzle Type	Single Nozzle
Environment Temp	5-40°C
Nozzle Temp	≤255°C
Hot Bed Temp	≤100°C
Slice Software	Cura/Repetier-Host/Simplify3D
Working Model	Online or Storage card offline
Power Supply	Input:115-230V Output:DC 24V
Working Power	300W
Resume Printing	YES
Auto-Leveling	YES
Filament Detection Sensor	YES



①	Filament Holder	⑤	BMG Extruder	⑨	Air Guide Nozzle	⑬	Tool Box
②	Axis	⑥	Slider	⑩	Nozzle Kit	⑭	USB Port
③	Filament Detector	⑦	Parallel Arm	⑪	Belt Adjustment Nut	⑮	SD Card Slot
④	Linear Guide	⑧	Touch Screen	⑫	Hot Bed	⑯	Power Switch



Main Parts



Bottom Shell



Top Shell and
Touch Screen



Axes



Leveling Switch

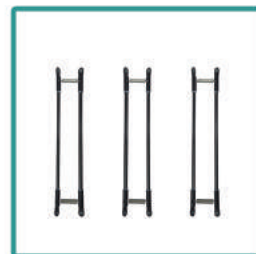

Parallel Arms



Effector Module



Extruder and Filament
Detection sensor



Filament Holder



USB Line



Power Line



Gift Parts List



Diagonal Pliers



Spatula



SD Card and Reader



Touch Screen Bracket



Screwdriver



Allen Wrench



Nozzle Kit



Heating Rod



Thermistor

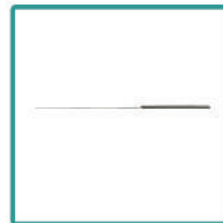

Clean Needle



Screws



Grease



Open-End Wrench



Brush



200g Filament



1. Take out all main parts and screws



2. Put the top shell on a flat surface, Please prevent the screen from being bumped during the assembly



3. Install the axis

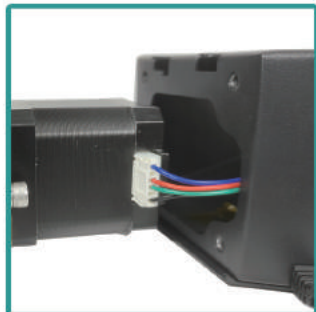

4. Plug the motor cable before putting the motor into the top shell



M4*22(Long)



5. Install the screws in the order from 1 to 4



6. One axis completed



7. Install the other two axes in the same way



8. Install the bottom shell.
The two logos marked in the photo should be face the same direction

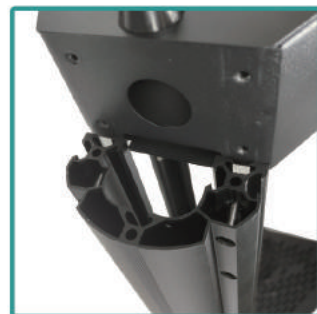

9. The top shell should be installed in the guide rail



10. Push the bottom shell down to the correct position



11. Install the screws for each axis in order from 1 to 4



12. Slide the touch screen bracket nut into the guide groove of the left axis



13. Move the touch screen bracket to one-third of the distance from the top shell

14. Rotate the knob clockwise to fix the touch screen bracket

15. Rotate the printer 180 degrees the logo is facing the front

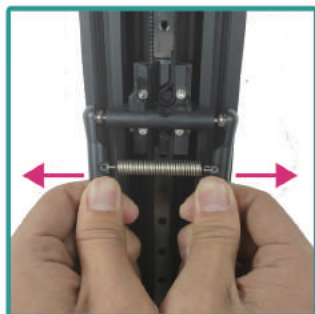

16. Pull the parallel arm to both sides and install it on the slider

17. Install the other two parallel arms in the same way

18. Install the effector module the logo on the effector module must face forward



19. Connect the connectors of the effector module to the main cable



20. The color of the connectors must match, two black connectors can be connected arbitrarily



21. Install the main cable connector



22. Put the main cable into the groove in the axis



M4*8 (short)

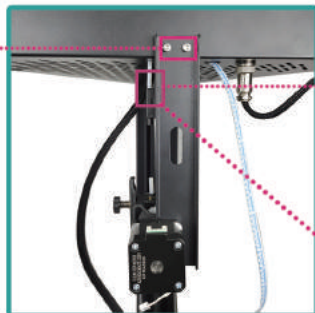

23. Install the extruder

The PTFE tube and the filament detection sensor entrance must be aligned



24. Extruder installation finished



25. Plug the filament detection sensor cable



26. Plug the extruder cable



27. Push the PTFE tube to the position marked with an arrow in the photo

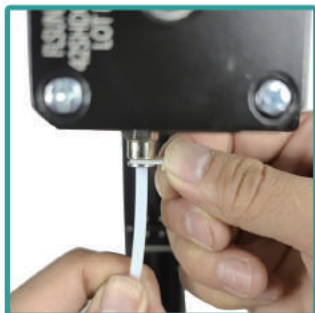

28. Fix the pneumatic connector with a buckle



29. Tie the PTFE tube and the main cable together at the location marked in the photo



M4*8 (short)



30. Assemble the filament holder



M4*8 (short)



31. Install the filament holder to the top case



32. The orientation of the filament holder should be as shown in the photo



View from the top



33. Remove the protective film from the hot bed.
The assembly is finished



◆ The default input voltage of the printer is **230V**, please make sure the printer is switched to your local voltage before turning on the power switch for the first time.



If your local voltage is **115V**, flip the red switch to the right to switch the voltage to **115V**



1. Use diagonal pliers to clean up the filaments on the nozzle



2. Connect the leveling switch



View from the right

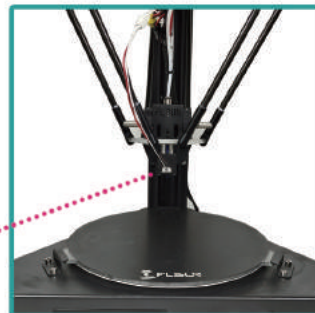

3. Install the leveling switch according to the direction on the photo



4. Click "Tools" icon on the homepage



5. Click "Auto-Level"

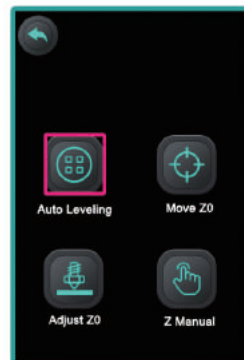

6. Click "Auto Leveling" on the subpage

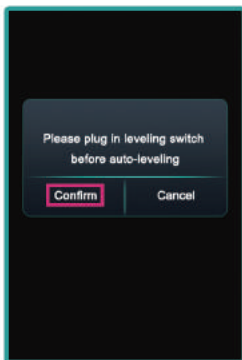

7. Click "Confirm"

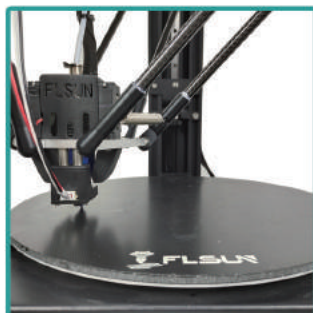

9. Remove the leveling switch and disconnect the connector after the auto leveling finished

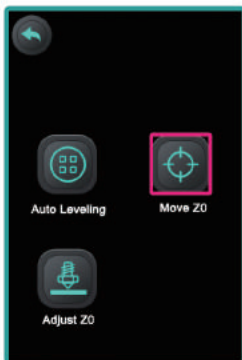

10. Click "Move Z0"

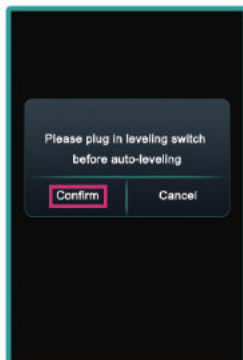

11. Make sure the leveling switch has been removed before click "Confirm"

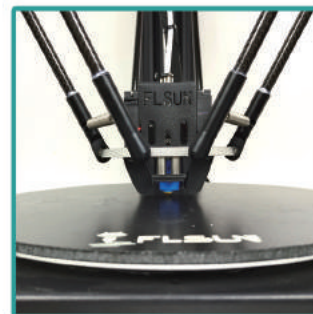

12. The nozzle moves closer to the hot bed

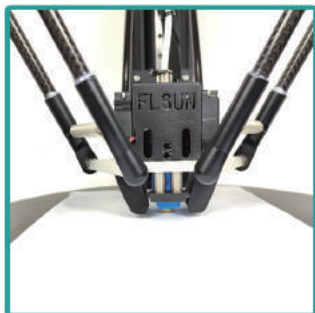

13. Put an A4 paper between the hot bed and the nozzle

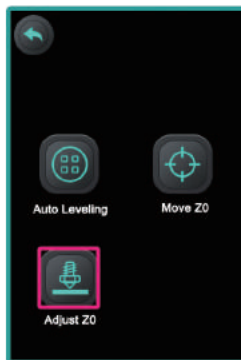

14. Click "Adjust Z0"

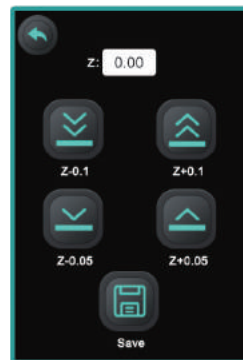

15. Click "Z+" and "Z-" to set the distance between the nozzle and the hot bed to the thickness of one layer A4 paper



16. The distance is optimal, when you feel a slight friction between the nozzle and the bed while slowly moving the paper backwards and forwards.

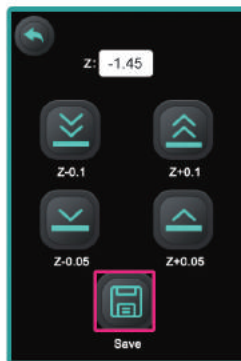

17. Click "Save"



18. Return to the homepage

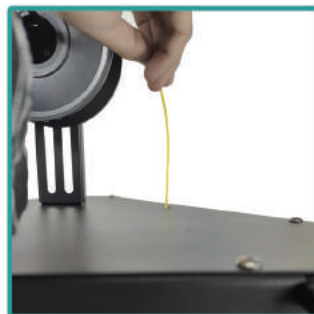

1. Straighten the end of the filament 10cm. Use diagonal pliers to cut the end of the filament into a bevel

2. This is how the filament should look after cutting

3. Push the filament through the PTFE tube in the top shell

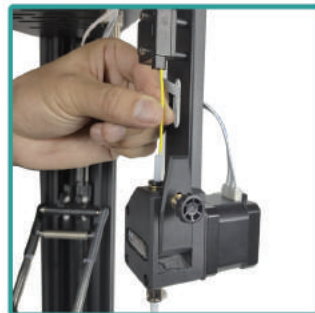

4. Push the filament through the filament detection sensor and insert it into the extruder

5. Turn on the power

6. Click "Tools" on the homepage



7. Click "Change"

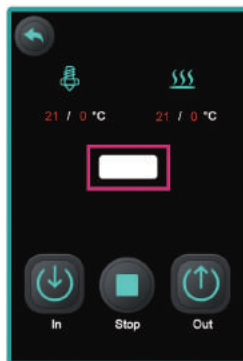

8. Click the white input box

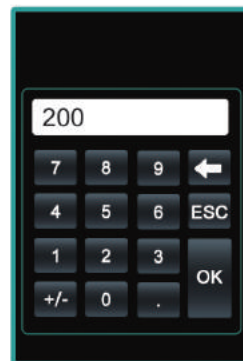

9. If you use PLA please enter 200 and click "OK"



10. Wait for the nozzle to heat up to 200°C, then click "in"

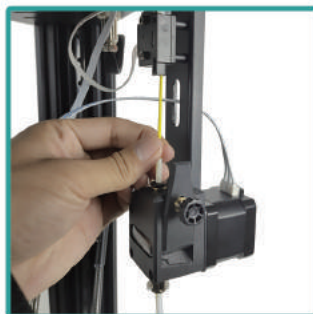

11. Push down the filaments at the same time



12. When the filament is extruded from the nozzle, click "Stop"



1. Insert SD card



2. Click "Print"

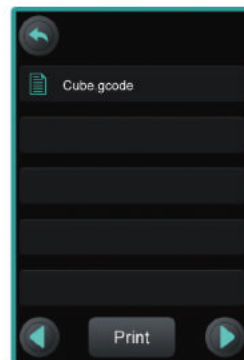

3. Select a test gcode to print

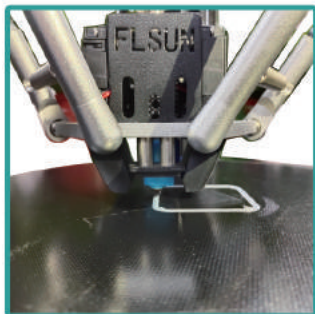

4. Monitor the extruded filament of the first layer



1. The nozzle is too close to the hot bed



2. Proper distance

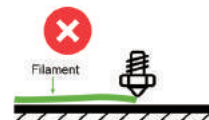

3. The nozzle is too far from the hot bed

5. If the nozzle is too close or too far away from the hot bed you can continue to adjust the height of Z0 while printing and the adjustment will be automatically saved



6. Click "Adjust Z"

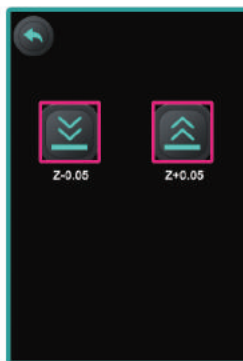

7. Click "Z-0.05" or "Z +0.05" to adjust the height of the Z



8. Adjust the distance between the nozzle and the hot bed to a proper distance then click "Cancel"



9. Clean the hot bed

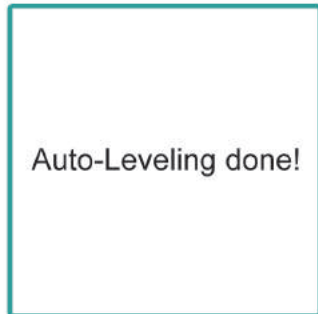

Auto-Leveling done!



1. Copy the CURA slicing software from the SD card to your computer then double-click to install

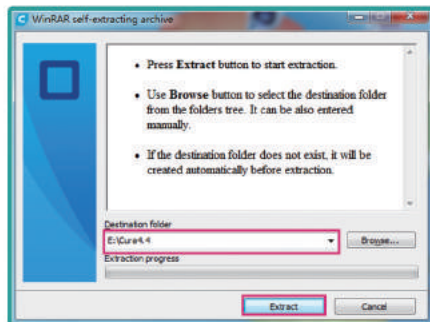

2. Select an installation location and click "Release"

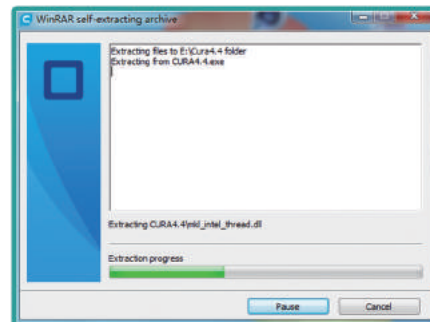

3. Wait for the installation to complete



4. Double-click the Cura shortcut on the computer desktop

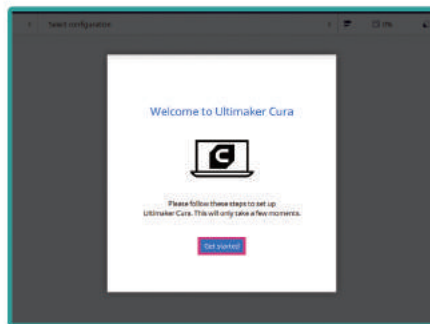

5. Click "Get started"

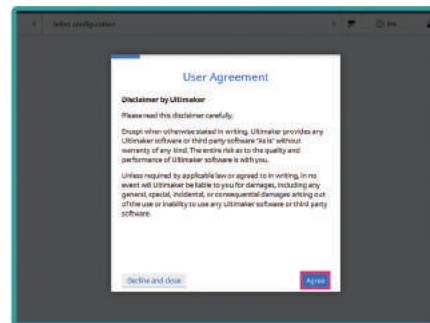

6. Click "Agree"

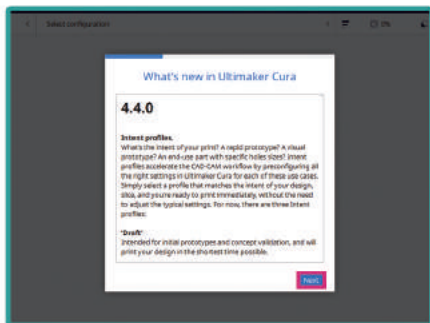

7. Click "Next"

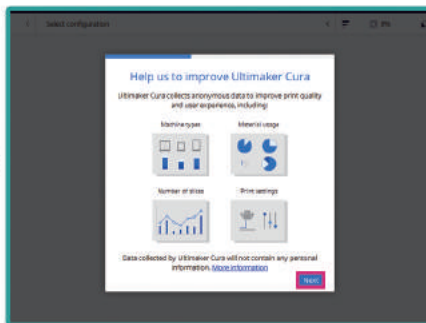

8. Click "Next"

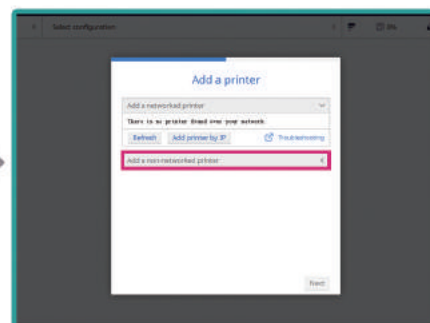

9. Click "Add a non-networked printer"

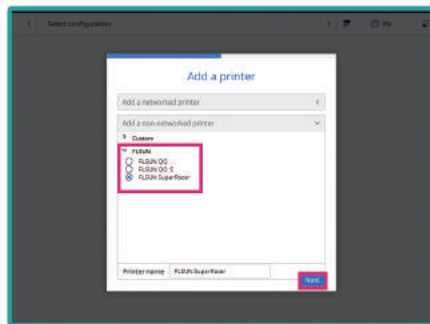

10. Select "FLSUN>Flsun SuperRacer"

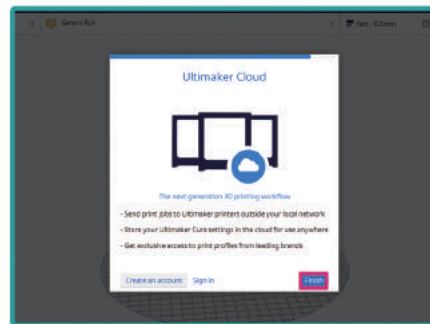

11. Click "Finish" to complete the installation



1. Insert the SD card into the card reader



2. Insert the card reader into the USB port of the computer

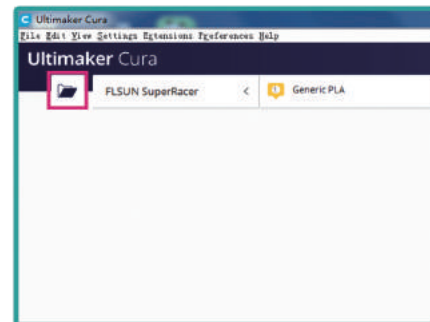

3. Double-click to open CURA, then click the folder icon in the upper left corner of the window

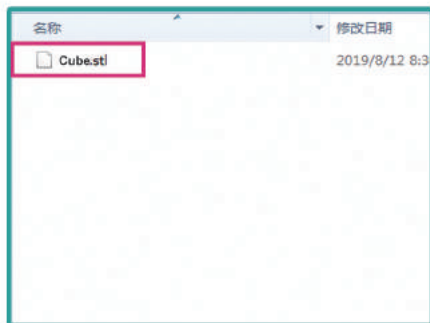

4. Select a supported file the CURA supports STL/OBJ/AMF/3DS format files

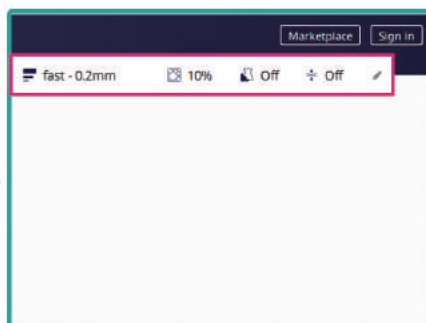

5. Click on the marked area in the photo to open the slice parameter configuration page

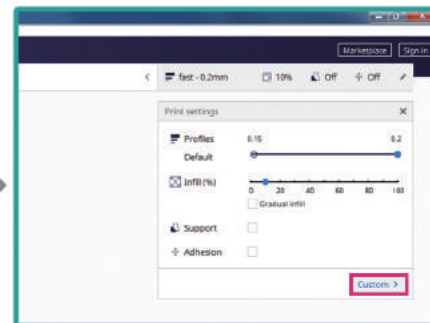

6. Click "Custom" to open more parameter configuration



Quality

- Layer Height: 0.2 mm
- Shell**
 - Wall Thickness: 0.8 mm
 - Wall Line Count: 2
 - Top/Bottom Thickness: 0.8 mm
 - Top Thickness: 0.8 mm
 - Top Layers: 4
 - Bottom Thickness: 0.8 mm
 - Bottom Layers: 4
 - Horizontal Expansion: 0 mm
- Infill**
 - Infill Density: 10 %
 - Infill Pattern: Gyroid**
- Material**
 - Printing Temperature: 220 °C**
 - Build Plate Temperature: 60 °C
 - Enable Retraction:
- Speed**
 - Print Speed: 150 mm/s
- Travel**
 - Z Hop When Retracted:
- Cooling**
 - Enable Print Cooling:
 - Fan Speed: 100 %
- Support**
 - Generate Support:
 - Support Placement: Everywhere
 - Support Overhang Angle: 50 °
- Build Plate Adhesion**
 - Build Plate Adhesion Type: None
- Dual Extrusion**

- 1
- 2
- 3
- 4
- 5
- 6
- 7
- 8
- 9
- 10
- 11
- 12
- 13
- 14
- 15
- 16
- 17
- 18
- 19
- 20
- 21
- 22

1. Set the printing height of each layer, SR supports a minimum layer height of 0.05mm.
2. The thickness of the walls in the horizontal direction, this value divided by the wall line width defines the number of walls.
3. The number of walls when calculated by the wall thickness, this value is rounded to a whole number.
4. The thickness of the top/bottom layers in the print.
5. The thickness of the top layers in the print.
6. The number of the top layers.
7. The thickness of the top layers in the print.
8. The number of the bottom layers.
9. Amount of offset applied to all polygons in each layer. Positive values can compensate for too big holes, negative values can compensate for too small holes.
10. Set fill rate.
11. Set the infill patterns, when the filling density is greater than 20%, the infill pattern should be "Lines"
12. Set the printing temperature of the nozzle, when printing PLA, due to the high speed the nozzle temperature should be set to 220°C.
13. Set the printing temperature of the hot bed.
14. Enable retraction, to avoid stringing or oozing during printing.
15. Set the printing speed, the default printing speed of SR is 150mm/s, and the maximum printing speed is 200mm/s.
16. Whenever a retraction is done, the build plate is lowered to create clearance between the nozzle and the print. It prevents the nozzle from hitting the print during travel.
17. Turn on the turbo fan. When printing a smaller model, turn on the turbo fan to prevent the model from warping.
18. Set the fan speed.
19. Enable generate support.
20. Support placement style, "Everywhere" means that support is not only generated from the hot bed, but also from the model itself, "Touching Buildplate" means the support will be generated only from the hot bed.
21. Support will be generated only when the angle between the model and the vertical direction is greater than this degree.
22. Build plate adhesion type. Select "Brim" mode to make the model better stick to the hot bed.

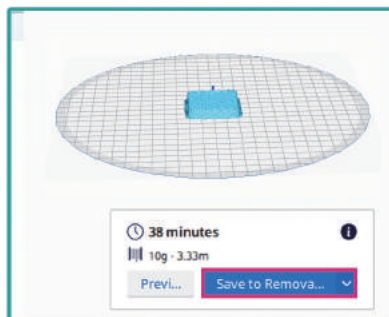
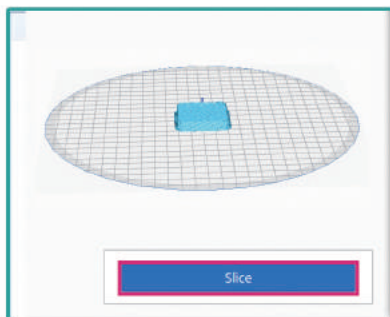

7.After adjusting to appropriate parameters, click "Slice"

8.Click"Save to Removable driver"

9.Insert the SD card into the printer card reader slot

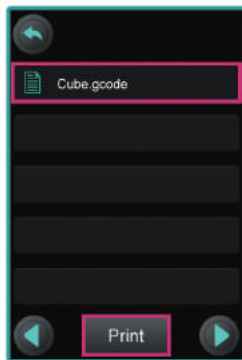

10.Click"Print"

11.Select the Gcode file and click "Print"

12.Printing will start automatically



Homepage

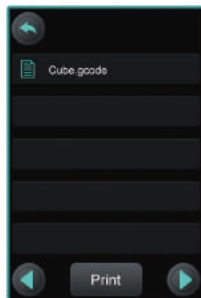

Select a gcode file to print

Heat:One-key preheating
Extrude:Extrude filaments
Move:Move XYZ axis separately
Change:Change filament
Auto-Level:Auto leveling page
Language:Switch display language



Cumulative printing time

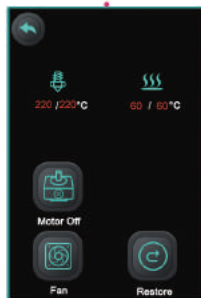

Motor Off:Unlock motor

Fan:Control the speed of the turbofan

Restore:Restore factory settings

You can find the firmware version, print size, UI version and contact information on the information page

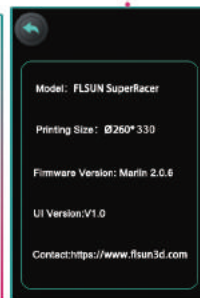

Model: FLSUN SuperRacer

Printing Size: Ø260*330

Firmware Version: Marlin 2.0.6

UI Version:V1.0

Contact:<https://www.flsun3d.com>



Settings Page

PLA:Preheat nozzle and hot bed to PLA printing temperature

ABS:Preheat nozzle and hot bed to ABS printing temperature

Cool Nozzle:Turn off nozzle heating

Cool Bed:Turn off the bed heating

Click on the two white input boxes to enter temp values



In:Feed filament

OUT:Retract filament

Click "1mm, 5mm and 10mm" to switch the extrusion distance of each step



Z-:Z direction up

Z-:Z direction down

Y+:Y direction up

Y-:Y direction down

X+:X direction up

X-:X direction down

X:X coordinate

Y:Y coordinate

Z:Z coordinate



Click the white input box to enter the temperature, the nozzle and hot bed will be preheated to the entered temperature value

In:Feed filament

OUT:Back filament

Stop:Stop extruding

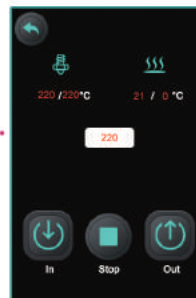

Auto Leveling:Start Auto Leveling

Move Z0:Move the nozzle close to the hot bed

Adjust Z0:Fine-tuning the distance between the nozzle and the hot bed

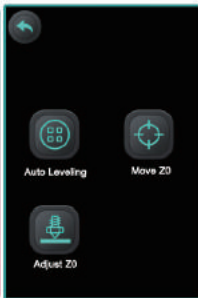

Select the language you want to display and click "Save"





Printing Page

Click the white input box to enter the temperature of the nozzle and hot bed



Instantaneous printing speed
Printed height



Click Z-0.05 and Z+0.05 to adjust the height of Z during printing

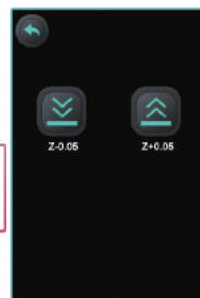

Click the up and down buttons to adjust the printing speed. When the printing speed exceeds the speed allowed by the printer, the quality may deteriorate.

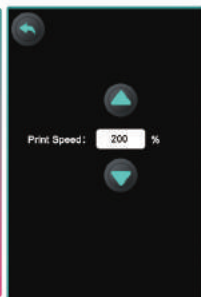

Click the up and down buttons to adjust the fan speed

Full Speed: Turbopan runs at full speed

Half Speed: Turbopan runs at Half speed

Turn Off: Turn Off Turbopan

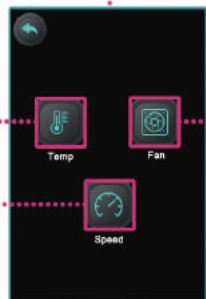
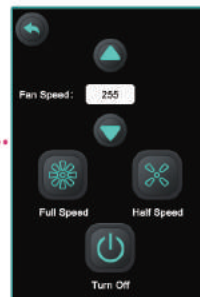

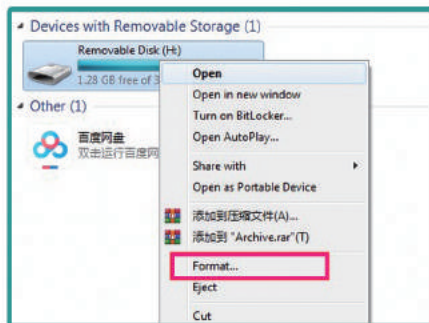

1.Format SD card

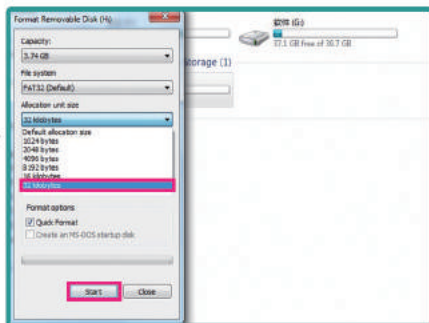

2.Select 32kilobytes format, click "start"

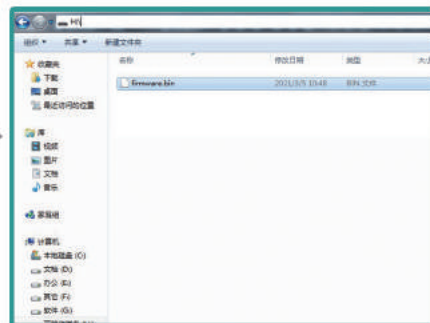

3.Copy the firmware to the root directory of the SD card



4.Insert the SD card into the card reader slot of the printer



5.Turn on the power



6.After the update finished the touch screen will display the home page



Q1 The model can't stick to the hot bed

Solution 1: Adjust Z0 height after Auto-leveling, until the height between nozzle and hot bed is the thickness of one layer of A4 paper.

Solution 2: Heat the hot bed to 60°C, then wipe the lattice platform with water or alcohol to remove grease and dust.

Solution 3: Add brim the model or rise the temperature of the hot bed in the slicer software.

Q2 The filament doesn't go easily into extruder

Cut the end of the filament into an oblique, straighten the head of the filament, and use automatic feeding. When the extruder starts working, push the filament by hand.

Q3 The filament cannot be pulled out from extruder smoothly when you change it

Solution 1: Pull out the PTFE tube from the extruder, then pull out the filament from the extruder.

Solution 2: If the PTFE tube has been deformed please change the PTFE tube first, insert the new PTFE tube till bottom, and tighten the pneumatic connector with the locking clip, then push down the new PTFE tube until it doesn't go further.

Q4 Nozzle clogging

Solution 1: Heat the nozzle to 220°C, then clean the nozzle with the nozzle cleaning needle

Solution 2: Heat the nozzle to 240°C, then click "Tools>Change>In" to use automatic feeding, to see if there is any filament extruded from the nozzle.

Solution 3: Clean the extruder gear and remove the filament fragment.

Solution 4: Change the nozzle module and cut the PTFE tube to a flat end and insert it to the bottom as far as possible.



Q5 Poor printing surface quality, with spots and wire drawing

Solution 1: Check if the linear guide and not parallel arm are loose and well lubricated.

Solution 2: To cut the PTFE tube to a flat end, heat the nozzle to 220°C, then re-insert the PTFE tube to nozzle module as far as possible.

Solution 3: Clean up the remaining filament debris on the extruder gear.

Q6 Solutions when display errors

error:TH-MAX The nozzle temperature sensor short circuit, please check the nozzle temperature sensor or the nozzle temperature sensor connector.

error:TB-MAX The hot-bed temperature sensor short circuit, please check the hot-bed temperature sensor or the hot-bed temperature sensor connector.

error:TH-MIN The nozzle temperature sensor broken circuit, please check the nozzle temperature sensor or the nozzle temperature sensor connector.

error:TB-MIN The hot-bed temperature sensor broken circuit, please check the hot-bed temperature sensor or the hot-bed temperature sensor connector.

error:TH-Runaway The temperature sensor at the nozzle fails or is suddenly disconnected during printing.

error:Heating failed The nozzle temperature sensor fails or suddenly disconnects during preheating or heating.

Q7 The printer can't be leveled, and the three axes don't go home .

Solution 1: Click "Set>Restore",and then do the Auto-Leveling again.

Solution 2: Check whether the red light on the limit switch is on. If the light on the limit switch is not on, it may be that the limit switch is damaged. swap with other limit switch and try again.

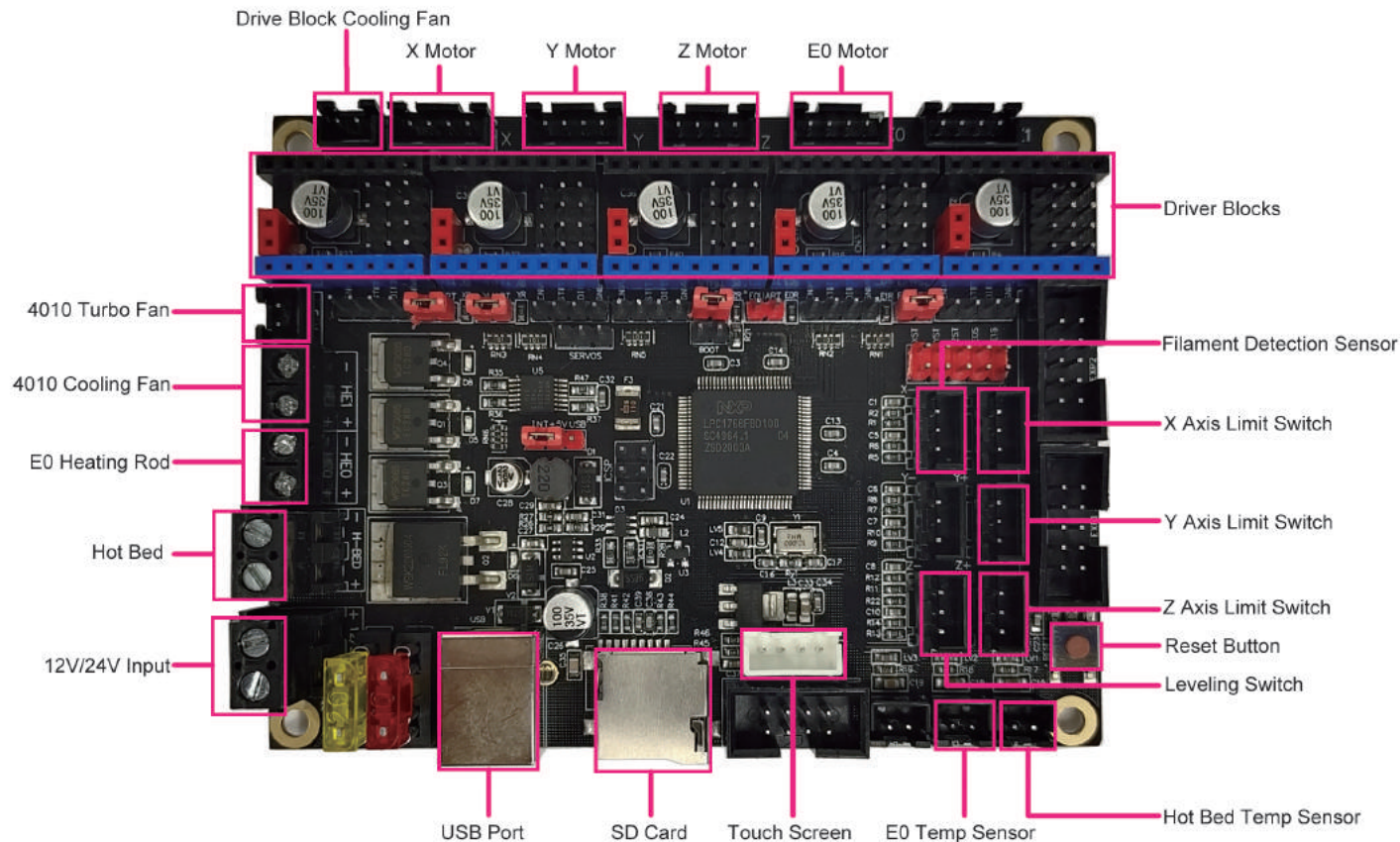



Use water or alcohol to clean the hot bed before **every print**. If there is dust or remaining filaments on the hot bed, the print will not stick to the hot bed well.

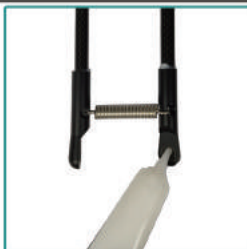



Apply grease to the contact between the parallel arm and the wide angle ball head, **do it once every 15 days**.



Iron sheet
Cylindrical gasket
Belt Adjustment Nut

Adjust the belt tightness, **do it once two months**. Loosen the two screws marked 1 and 2 in the photo, and then turn the belt adjusting nut clockwise. When there is no gap between the cylindrical gasket and the iron sheet (pointed by the finger) tighten screws 1 and 2.

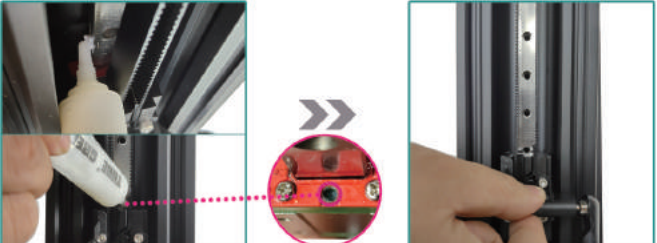
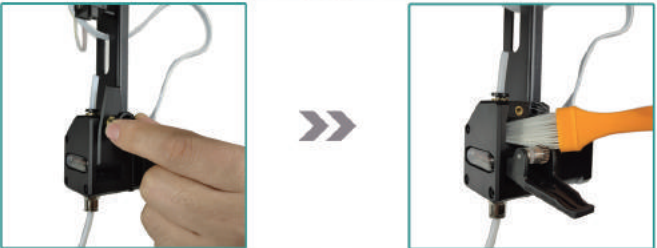
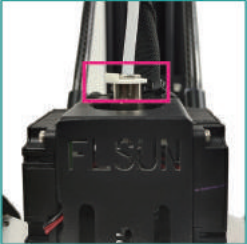

	<p>Squeeze the grease into the small hole of the slider and sides of the linear guide, then slide the slider up and down to spread the grease evenly, do it once every 15 days.</p>
	<p>Completely loosen the adjusting knob of the extruder, open the extruder, and use the brush to clean the extruder gears and residual filaments inside, do it once every 7 days.</p>
	 <p>Regularly check whether the buckle fixing the pneumatic connector on the extruder and the effector module has fallen off.</p>



SR Facebook Group



WhatsApp



Facebook



Support Facebook:<https://www.facebook.com/FlsunChow/>

Support Email:service@flsund3d.com

Support Skype:FLSUN_Zhang

Official Website:<https://www.flsun3d.com/>

Official FB Group:<https://www.facebook.com/groups/336951057403890>